



## TECHNICAL GUIDE

### SINGLE PIECE VARIABLE SPEED ECM COMMUNICATING AIR HANDLERS WITH ELECTRONIC EXPANSION VALVE

FOR USE WITH SPLIT-SYSTEM COOLING & HEAT PUMPS

### MODELS: AVV SERIES



ISO 9001  
Certified Quality  
Management System

Due to continuous product improvement, specifications are subject to change without notice.

Visit us on the web at:

[www.upgnet.com](http://www.upgnet.com) and [www.york.com](http://www.york.com)

Additional rating information can be found at:

[www.ahridirectory.org](http://www.ahridirectory.org)

#### WARRANTY SUMMARY

Standard 5-year limited parts warranty.

**Extended 10-year limited parts warranty** when product is registered online within 90 days of purchase for replacement or closing for new home construction.

## DESCRIPTION

The AVV Air Handler model line offers the ultimate in comfort, low sound and application flexibility. This unit can be used in upflow, downflow, horizontal right and horizontal left applications with no additional parts or kits.

All AVV air handlers employ a high efficiency ECM variable speed, constant CFM blower motor and a factory mounted EEV valve. The AVV product line is specifically designed to match with the YZV and YXV high-efficiency variable capacity outdoor units. The AVV is designed to work as part of a 4-wire communicating system which employs the *Hx™* Wi-Fi Thermostat for control.

## FEATURES

**Rigid Case Construction** - an interior endoskeleton provides structural support eliminating screw heads protruding from the side of the cabinet that could damage property when being installed.

**Cabinet** - Constructed of heavy gauge galvanized steel with a primer and finish coat providing a high quality corrosion resistant finish.

**MaxAlloy™ Coil** - Long life aluminum coils built to deliver lasting performance, efficiency and reliability.

**Foil faced insulation** - The entire cabinet is insulated with a single piece of cleanable foil faced insulation retained by the endoskeleton. The cabinet design is such that all edges of the insulation are contained.

**Electronic Expansion Valve (EEV)** - Factory installed and sized to match with specific YZV and YXV high-efficiency variable capacity outdoor units.

**Compact Cabinet** - With the coil and access doors removed the cabinet has a 20.5" casing depth in all models, which provide ease of attic access and space constrained applications.

**Thermoset Drain Pan** - Corrosion and UV resistant with a positive slope for proper drainage. Low water retention design maximizes indoor air quality and consumer comfort.

**Low Leakage Cabinet Design** - Fully gasketed doors minimizes air leakage to no more than 2% when measured at 1.0" esp. minimizing conditioned air leakage and infiltration.

**Integrated Filter Rack** - All models have an internal filter rack for use with 1" thick standard size filters.

**Electric Heat Kits** - 208/230V single and three phase field installed electric heat kits are available from 5 through 25 kW. Make sure to check the technical guide for proper application. Electric heat kits are common between the different air handler families including the modular designs.

**ECM Variable Speed Motors** - All models use variable speed ECM motors for efficient, quiet operation. The blower can be independently controlled to optimize the system for specific comfort requirements.

**Duct Flange** - Duct flanges are supplied to be field installed when required.

**LIST OF SECTIONS**

DESCRIPTION .....	1
FEATURES .....	1
NOMENCLATURE .....	2
DIMENSIONS & DUCT CONNECTION DIMENSIONS .....	3
DIMENSIONS .....	3
COIL TECHNICAL DATA .....	3
COOLING CAPACITY .....	4
PHYSICAL & ELECTRICAL DATA - COOLING ONLY .....	5
APPLICATION FACTORS - RATED CFM VS. ACTUAL CFM .....	5
ELECTRICAL DATA - COOLING ONLY .....	5
ELECTRICAL HEAT - MINIMUM FAN SPEED .....	6
ELECTRIC HEAT PERFORMANCE DATA: 208/230-1-60 & 208/230-3-60 .....	6
ELECTRICAL DATA FOR SINGLE SOURCE POWER SUPPLY: 208/230-1-60 .....	7
ELECTRICAL DATA FOR MULTI-SOURCE POWER SUPPLY: 208/230-1-60 .....	9
ELECTRICAL DATA FOR SINGLE SOURCE POWER SUPPLY: 208/230-3-60 .....	10
ELECTRICAL DATA FOR MULTI-SOURCE POWER SUPPLY: 208/230-3-60 .....	11
POWER WIRING - LINE CONNECTIONS .....	11
ACCESSORIES .....	11
COMBUSTIBLE FLOOR BASE ACCESSORY .....	12
LIMITATIONS .....	12
TYPICAL APPLICATIONS .....	12
TYPICAL THERMOSTAT CONNECTION .....	13
AIR FLOW DATA (CFM) .....	14

**NOMENCLATURE**

<b>PRODUCT TYPE</b>	<b>A</b>	A = Single Piece Air Handler
<b>POSITION MOTOR TYPE</b>	<b>V</b>	P = Multi PSC E = Multi Std ECM V = Multi VS ECM Z = Compact Up Std ECM
<b>OPTIONS</b>	<b>V</b>	C = Communications Ready V = Communication and Variable - = Standard (No Options)
<b>NOMINAL UNIT CAPACITY</b>	<b>36</b>	18 = 1.5 Ton      42 = 3.5 Ton 24 = 2 Ton      48 = 4-Ton 25 = 2 Ton      49 = 4-Ton 30 = 2.5 Ton    50 = 5-Ton 36 = 3 Ton      60 = 5-Ton 37 = 3 Ton      61 = 5-Ton 38 = 3 Ton
<b>CABINET WIDTH</b>	<b>B</b>	A = 14.5" B = 17.5" C = 21.0" D = 24.5"
<b>TXV INDICATOR</b>	<b>E1</b>	BA-BF = Valve Size E1-E9 = Valve Size X = No Valve
<b>VOLTAGE (Voltage-Phase-Hertz)</b>	<b>2</b>	1 = 115-1-60      3 = 208/230-3-60 2 = 208/230-1-60    4 = 460-3-60
<b>GENERATION (MAJOR REVISION)</b>	<b>1</b>	1 = 1st Gen 2 = 2nd Gen etc.
<b>STYLE LETTER (MINOR REVISION) NOT USED FOR ORDERING</b>	<b>A</b>	A = Style A B = Style B etc.

**DIMENSIONS & DUCT CONNECTION DIMENSIONS**

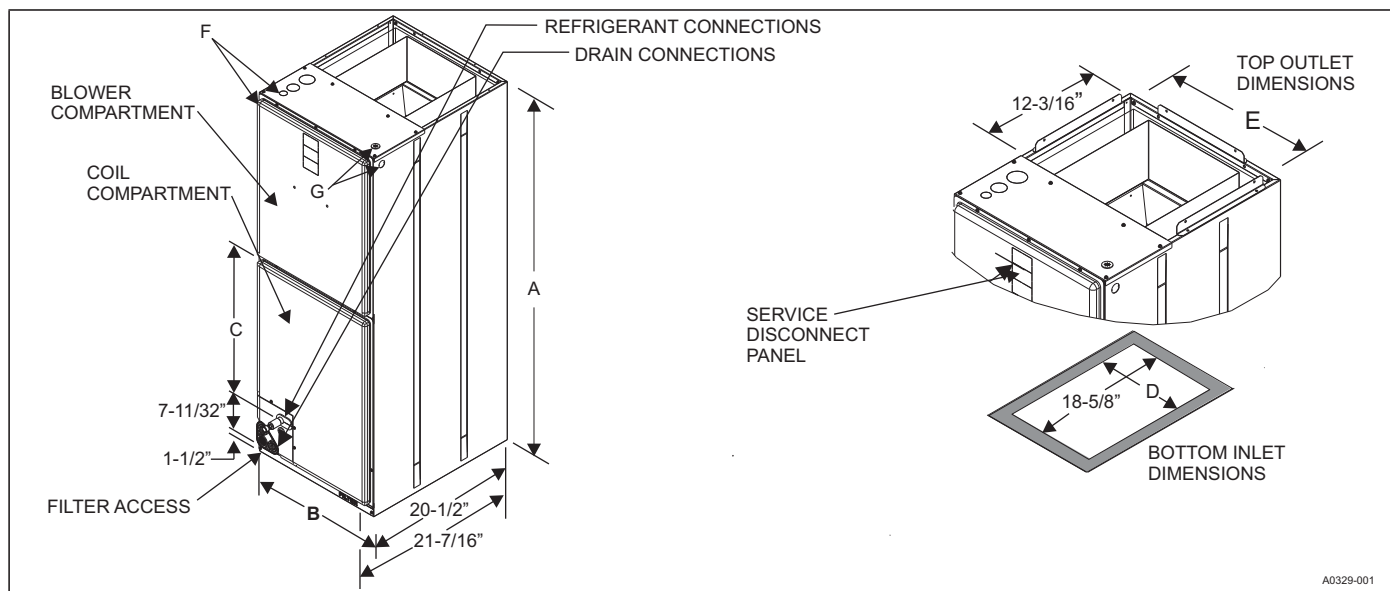

**DIMENSIONS**

Models	Dimensions <sup>1</sup>					Wiring Knockouts <sup>2</sup>		Refrigerant Connections Line Size		
	A	B	C	D	E	F	G	Liquid	Vapor	
	Height	Width				Power	Control			
AVV25B	47-1/2	17-1/2	19-1/2	14-1/4	16-1/2	7/8 (1/2) 1-3/8 (1) 1-23/32 (1-1/4)	7/8 (1/2)	3/8	3/4	
AVV37B	47-1/2	17-1/2	19-1/2	14-1/4	16-1/2					
AVV37C	51-1/2	21	22-5/8	17-3/4	20					
AVV38B	51-1/2	17-1/2	22-5/8	17-3/4	20					
AVV38C	55-3/4	21	26-7/8	17-3/4	16-1/2					
AVV49C	55-3/4	21	26-7/8	17-3/4	20					
AVV49D	51-1/2	24-1/2	26-5/8	21-3/4	23-1/2			7/8	3/8	7/8
AVV50C	60	21	31-3/8	17-3/4	20					
AVV50D	60	24-1/2	31-3/8	21-3/4	23-1/2					
AVV61C	60	21	31-3/8	17-3/4	20					
AVV61D	60	24-1/2	31-3/8	21-3/4	23-1/2					

1. All dimensions are in inches.
2. Actual size (Conduit size in parenthesis.).

**COIL TECHNICAL DATA**

Models	Application	Refrigeration Tubing Connection Types	Face Area (Sq. Ft.)	Rows Deep	Fins Per Inch	Coil Size	Tube Geometry	Tube Diameter	Fin Type
25B	Cooling /Heat Pump	Sweat	7.1	2	14	(3) 20 x 17.1	1 x 0.866	3/8	Sine Wave
37B	Cooling /Heat Pump	Sweat	7.1	2	14	(3) 20 x 17.1	1 x 0.866	3/8	Sine Wave
37C	Cooling /Heat Pump	Sweat	7.1	2	14	(3) 20 x 17.1	1 x 0.866	3/8	Sine Wave
38B	Cooling /Heat Pump	Sweat	TBD	TBD	TBD	TBD	1 x 0.866	3/8	Sine Wave
38C	Cooling /Heat Pump	Sweat	6.7	3	12	(2) 28 x 17.1	1 x 0.866	3/8	Sine Wave
49C	Cooling /Heat Pump	Sweat	6.7	3	12	(2) 28 x 17.1	1 x 0.866	3/8	Sine Wave
49D	Cooling /Heat Pump	Sweat	6.7	3	12	(2) 28 x 17.1	1 x 0.866	3/8	Sine Wave
50C	Cooling /Heat Pump	Sweat	7.6	3	12	(2) 32 x 17.1	1 x 0.866	3/8	Sine Wave
50D	Cooling /Heat Pump	Sweat	7.6	3	12	(2) 32 x 17.1	1 x 0.866	3/8	Sine Wave
61C	Cooling /Heat Pump	Sweat	7.6	3	12	(2) 32 x 17.1	1 x 0.866	3/8	Sine Wave
61D	Cooling /Heat Pump	Sweat	7.6	3	12	(2) 32 x 17.1	1 x 0.866	3/8	Sine Wave

**COOLING CAPACITY<sup>1</sup>**

Models	Rated CFM <sup>2</sup>	Entering Air Dry/Wet Bulb (°F)	MBH@ Evap. Temp. and Corresponding R-410A Pressure (°F/PSIG)			
			35/107.9	40/118.9	45/130.7	50/143.3
AVV25B	780	85/72	55.1	48.8	40.7	31.5
		80/67	45.5	37.3	29.3	22.1
		75/62	33.9	27.8	20.8	14.2
		70/57	26.1	19.5	14.3	10.5
AVV37B	1200	85/72	79.3	69.5	57.4	44.8
		80/67	64.0	53.3	42.6	30.7
		75/62	50.0	39.0	29.9	19.9
		70/57	37.3	29.0	20.2	15.4
AVV37C	1200	85/72	79.3	69.5	57.4	44.8
		80/67	64.0	53.3	42.6	30.7
		75/62	50.0	39.0	29.9	19.9
		70/57	37.3	29.0	20.2	15.4
AVV38B	TBD	TBD	TBD	TBD	TBD	TBD
AVV38C	1200	85/72	95.7	83.7	72.7	59.6
		80/67	77.6	66.7	54.7	41.6
		75/62	62.1	50.8	39.0	26.7
		70/57	47.6	37.4	26.2	19.8
AVV49C	1500	85/72	100.9	89.3	76.9	61.9
		80/67	82.7	70.7	57.6	44.1
		75/62	65.7	53.9	41.0	28.0
		70/57	50.2	38.5	27.7	21.2
AVV49D	1600	85/72	105.5	93.5	80.5	65.0
		80/67	86.9	74.2	60.4	45.6
		75/62	68.6	56.0	42.5	29.4
		70/57	52.5	40.2	28.3	21.6
AVV50C	1600	85/72	112.6	99.2	83.5	68.6
		80/67	91.9	77.3	60.5	39.7
		75/62	72.1	44.3	38.5	29.3
		70/57	43.2	37.1	28.2	23.2
AVV50D	1600	85/72	112.6	99.2	83.5	68.6
		80/67	91.9	77.3	60.5	39.7
		75/62	72.1	44.3	38.5	29.3
		70/57	43.2	37.1	28.2	23.2
AVV61C	1600	85/72	112.6	99.2	83.5	68.6
		80/67	91.9	77.3	60.5	39.7
		75/62	72.1	44.3	38.5	29.3
		70/57	43.2	37.1	28.2	23.2
AVV61D	1800	85/72	121.2	107.6	92.9	73.3
		80/67	99.3	84.6	67.9	41.1
		75/62	77.4	45.0	39.9	31.1
		70/57	44.1	38.7	29.9	24.9

**NOTES:**

1. Actual capacity varies with the outdoor AC or HP that is used with the system.
2. Airflow is calculated for each system tonnage.

**PHYSICAL & ELECTRICAL DATA - COOLING ONLY**

Models	AVV25B	AVV37B	AVV37C	AVV38B	AVV38C	AVV49C	AVV49D	AVV50C	AVV50D	AVV61C	AVV61D	
Blower - Diameter x Width	10 x 8	10 x 8	11 x 10	TBD	11 x 10	11 x 10	11 x 10	11 x 10	11 x 10	11 x 10	11 x 10	
Motor	HP	1/2 HP	1/2 HP	1/2 HP	TBD	1/2 HP	3/4 HP	3/4 HP	3/4 HP	3/4 HP	3/4 HP	
	Nominal RPM	1050	1050	1050	TBD	1050	1050	1050	1050	1050	1050	
Voltage	208/230	208/230	208/230	TBD	208/230	208/230	208/230	208/230	208/230	208/230	208/230	
Full Load Amps @230V	4.5	4.5	4.5	TBD	4.5	7.0	7.0	7.0	7.0	7.0	7.0	
Filter <sup>1</sup>	Type	DISPOSABLE OR PERMANENT										
	Size	16 x 20 x 1	16 x 20 x 1	20 x 20 x 1	TBD	20 x 20 x 1	20 x 20 x 1	22 x 20 x 1	20 x 20 x 1	22 x 20 x 1	20 x 20 x 1	22 x 20 x 1
	Permanent Type Kit	1PF0601	1PF0601	1PF0602	TBD	1PF0602	1PF0602	1PF0603	1PF0602	1PF0603	1PF0602	1PF0603
Shipping/Operating Weights (lbs.)	119/113	119/113	120/114	TBD	158/150	158/150	163/153	175/165	180/170	175/165	180/170	

**NOTES:**

1. Field supplied.

**kW & MBH CONVERSIONS - FOR TOTAL POWER INPUT REQUIREMENT**

For a power distribution voltage that is different than the provided nominal voltage, multiply the kW and MBH data from the table by the conversion factor in the following table.

DISTRIBUTION POWER	NOMINAL VOLTAGE	CONVERSION FACTOR
208V	240V	0.75
220V	240V	0.84
230V	240V	0.92

**APPLICATION FACTORS - RATED CFM VS. ACTUAL CFM**

% Of Rated Airflow (CFM)	80%	90%	100%	110%	120%
Capacity Factor	0.96	0.98	1.00	1.02	1.03

**ELECTRICAL DATA - COOLING ONLY**

Models	Motor FLA <sup>1</sup>		Minimum Circuit Ampacity		MOP <sup>2</sup>
	208V	230V	208V	230V	
25B / 37B / 37C / 38B / 38C	5.0	4.5	6.3	5.6	15
49C / 49D / 50C / 50D / 61C / 61D	7.3	7.0	9.1	8.8	15

1. FLA = Full Load Amps

2. MOP = Maximum Overcurrent Protection device; must be HACR type circuit breaker or time delay fuse. Refer to the latest edition of the National Electric Code or in Canada the Canadian electrical Code and local codes to determine correct wire sizing.

**ELECTRICAL HEAT - MINIMUM FAN SPEED**

Heater Kit Models <sup>1,2,3</sup>	Nom. kW @240V	Air Handler Models										
		AVV25B	AVV37B	AVV37C	AVV38B	AVV38C	AVV49C	AVV49D	AVV50C	AVV50D	AVV61C	AVV61D
6HK(0,1)6500206	2.4kW	Med Lo (D)	Med Lo (D)	Med Lo (D)	TBD	Med Lo (D)	Med Lo (D)	Med Lo (D)	Med Lo (D)	Med Lo (D)	Med Lo (D)	Med Lo (D)
6HK(0,1)6500506	4.8kW	Med Lo (D)	Med Lo (D)	Med (C)	TBD	Med (C)	Med Lo (D)	Med Lo (D)	Med Lo (D)	Med Lo (D)	Med Lo (D)	Med Lo (D)
6HK(0,1)6500806	7.7kW	Med Lo (D)	Med Lo (D)	Med Hi (B)	TBD	Med Hi (B)	Med Lo (D)	Med Lo (D)	Med Lo (D)	Med Lo (D)	Med Lo (D)	Med Lo (D)
6HK(0,1)6501006 6HK36501025	9.6kW	Med Lo (D)	Med Lo (D)	Med Hi (B)	TBD	Med Hi (B)	Med Lo (D)	Med Lo (D)	Med Lo (D)	Med Lo (D)	Med Lo (D)	Med Lo (D)
6HK(1,2)6501306	12.5kW	Med (C)	Med (C)	Med Hi (B)	TBD	Med Hi (B)	Med Lo (D)	Med Lo (D)	Med Lo (D)	Med Lo (D)	Med Lo (D)	Med Lo (D)
6HK(1,2)6501506 6HK36501525	14.4kW	-	Med Hi (B)	Med Hi (B)	TBD	Med Hi (B)	Med (C)	Med (C)	Med (C)	Med (C)	Med (C)	Med Lo (D)
6HK(1,2)6501806 6HK36501825	17.3kW	-	Med Hi (B)	Med Hi (B)	TBD	Med Hi (B)	Med (C)	Med Hi (B)	Med (C)	Med Hi (B)	Med (C)	Med (C)
6HK(1,2)6502006 6HK46502025	19.2kW	-	Med Hi (B)	Hi (A)	TBD	Hi (A)	Med Hi (B)	Hi (A)	Med Hi (B)	Hi (A)	Med Hi (B)	Med Hi (B)
6HK(1,2)6502506 6HK46502525	24kW	-	-	-	TBD	-	-	Hi (A)	-	Hi (A)	-	Med Hi (B)

- (0,1) - 0 = no service disconnect OR 1 = with service disconnect.
- (1,2) - 1 = with service disconnect, no breaker jumper bar OR 2 = with service disconnect & breaker jumper bar.
- 6HK3 = 3-Phase with terminal block connectors only, 6HK4 = 3-Phase with service disconnect.

**ELECTRIC HEAT PERFORMANCE DATA: 208/230-1-60 & 208/230-3-60**

Heater Models <sup>1,2,3</sup>		Nominal kW @240V	Total Heat <sup>4</sup>				kW Staging			
			kW		MBH		W1 Only		W1 + W2	
			208V	230V	208V	230V	208V	230V	208V	230V
1PH	6HK(0,1)6500206	2.4	1.8	2.2	6.2	7.5	1.8	2.2	1.8	2.2
	6HK(0,1)6500506	4.8	3.6	4.4	12.3	15	3.6	4.4	3.6	4.4
	6HK(0,1)6500806	7.7	5.8	7.1	19.7	24.1	5.8	7.1	5.8	7.1
	6HK(0,1)6501006	9.6	7.2	8.8	24.6	30.1	7.2	8.8	7.2	8.8
	6HK(1,2)6501306	12.5	9.4	11.5	32	39.2	3.1	3.8	9.4	11.5
	6HK(1,2)6501506	14.4	10.8	13.2	36.9	45.1	3.6	4.4	10.8	13.2
	6HK(1,2)6501806	17.3	13	15.9	44.3	54.2	6.5	7.9	13	15.9
	6HK(1,2)6502006	19.2	14.4	17.6	49.2	60.2	7.2	8.8	14.4	17.6
6HK(1,2)6502506	24	18	22	61.5	75.2	7.2	8.8	18	22	
3PH	6HK36501025	9.6	7.2	8.8	24.6	30.1	7.2	8.8	7.2	8.8
	6HK36501525	14.4	10.8	13.2	36.9	45.1	10.8	13.2	10.8	13.2
	6HK36501825	17.3	13	15.9	44.3	54.2	13	15.9	13	15.9
	6HK46502025	19.2	14.4	17.6	49.2	60.2	7.2	8.8	14.4	17.6
	6HK46502525	24	18	22	61.5	75.2	9	11	18	22

**NOTES:**

- (0,1) - 0 = no service disconnect OR 1 = with service disconnect.
- (1,2) - 1 = with service disconnect, no breaker jumper bar OR 2 = with service disconnect & breaker jumper bar.
- 6HK3 = 3-Phase with terminal block connectors only, 6HK4 = 3-Phase with service disconnect.
- For different power distributions, see "kW & MBH CONVERSIONS" table on Page 5.

**ELECTRICAL DATA FOR SINGLE SOURCE POWER SUPPLY: 208/230-1-60**

Air Handler Models	Heater Models <sup>1,2</sup>	Heater Amps @240V	Field Wiring			
			Min. Circuit Ampacity		MOP <sup>3</sup>	
			208V	230V	208V	230V
AVV25B	6HK(0,1)6500206	10	17.1	17.6	20	20
	6HK(0,1)6500506	20	27.9	29.5	30	30
	6HK(0,1)6500806	32	41.1	44.2	45	45
	6HK(0,1)6501006	40	49.5	53.5	50	60
	6HK(1,2)6501306	52	62.7	68.1	70	70
AVV37B	6HK(0,1)6500206	10	114.4	125.2	20	20
	6HK(0,1)6500506	20	49.5	53.5	30	30
	6HK(0,1)6500806	32	71.2	77.4	45	45
	6HK(0,1)6501006	40	84.4	92.0	50	60
	6HK(1,2)6501306	52	92.8	101.3	70	70
	6HK(1,2)6501506	60	114.4	125.2	80	80
	6HK(1,2)6501806	72	6.3	5.6	90	100
	6HK(1,2)6502006	80	6.3	5.6	100	110
AVV37C	6HK(0,1)6500206	10	17.1	17.6	20	20
	6HK(0,1)6500506	20	27.9	29.5	30	30
	6HK(0,1)6500806	32	41.1	44.2	45	45
	6HK(0,1)6501006	40	49.5	53.5	50	60
	6HK(1,2)6501306	52	62.7	68.1	70	70
	6HK(1,2)6501506	60	71.2	77.4	80	80
	6HK(1,2)6501806	72	84.4	92.0	90	100
	6HK(1,2)6502006	80	92.8	101.3	100	110
AVV38B	TBD	TBD	TBD	TBD	TBD	TBD
AVV38C	6HK(0,1)6500206	10	17.1	17.6	20	20
	6HK(0,1)6500506	20	27.9	29.5	30	30
	6HK(0,1)6500806	32	41.1	44.2	45	45
	6HK(0,1)6501006	40	49.5	53.5	50	60
	6HK(1,2)6501306	52	62.7	68.1	70	70
	6HK(1,2)6501506	60	71.2	77.4	80	80
	6HK(1,2)6501806	72	84.4	92.0	90	100
AVV49C	6HK(0,1)6500206	10	19.9	20.7	25	25
	6HK(0,1)6500506	20	30.8	32.7	35	35
	6HK(0,1)6500806	32	44.0	47.3	45	50
	6HK(0,1)6501006	40	52.4	56.6	60	60
	6HK(1,2)6501306	52	65.6	71.3	70	80
	6HK(1,2)6501506	60	74.0	80.5	80	90
	6HK(1,2)6501806	72	87.3	95.2	90	100
	6HK(1,2)6502006	80	95.7	104.4	100	110
AVV49D	6HK(0,1)6500206	10	19.9	20.7	25	25
	6HK(0,1)6500506	20	30.8	32.7	35	35
	6HK(0,1)6500806	32	44.0	47.3	45	50
	6HK(0,1)6501006	40	52.4	56.6	60	60
	6HK(1,2)6501306	52	65.6	71.3	70	80
	6HK(1,2)6501506	60	74.0	80.5	80	90
	6HK(1,2)6501806	72	87.3	95.2	90	100
	6HK(1,2)6502006	80	95.7	104.4	100	110
	6HK(1,2)6502506	100	117.3	128.3	125	150

Continued on next page. See notes at end of table.

**ELECTRICAL DATA FOR SINGLE SOURCE POWER SUPPLY: 208/230-1-60 (Continued)**

Air Handler Models	Heater Models <sup>1,2</sup>	Heater Amps @240V	Field Wiring			
			Min. Circuit Ampacity		MOP <sup>3</sup>	
			208V	230V	208V	230V
AVV50C	6HK(0,1)6500206	10	9.1	8.8	25	25
	6HK(0,1)6500506	20	9.1	8.8	35	35
	6HK(0,1)6500806	32	9.1	8.8	45	50
	6HK(0,1)6501006	40	9.1	8.8	60	60
	6HK(1,2)6501306	52	9.1	8.8	70	80
	6HK(1,2)6501506	60	9.1	8.8	80	90
	6HK(1,2)6501806	72	9.1	8.8	90	100
AVV50D	6HK(1,2)6502006	80	9.1	8.8	100	110
	6HK(0,1)6500206	10	19.9	20.7	25	25
	6HK(0,1)6500506	20	30.8	32.7	35	35
	6HK(0,1)6500806	32	44.0	47.3	45	50
	6HK(0,1)6501006	40	52.4	56.6	60	60
	6HK(1,2)6501306	52	65.6	71.3	70	80
	6HK(1,2)6501506	60	74.0	80.5	80	90
	6HK(1,2)6501806	72	87.3	95.2	90	100
AVV61C	6HK(1,2)6502006	80	95.7	104.4	100	110
	6HK(0,1)6500206	10	19.9	20.7	25	25
	6HK(0,1)6500506	20	30.8	32.7	35	35
	6HK(0,1)6500806	32	44.0	47.3	45	50
	6HK(0,1)6501006	40	52.4	56.6	60	60
	6HK(1,2)6501306	52	65.6	71.3	70	80
	6HK(1,2)6501506	60	74.0	80.5	80	90
	6HK(1,2)6501806	72	87.3	95.2	90	100
AVV61D	6HK(1,2)6502006	80	95.7	104.4	100	110
	6HK(0,1)6500206	10	19.9	20.7	25	25
	6HK(0,1)6500506	20	30.8	32.7	35	35
	6HK(0,1)6500806	32	44.0	47.3	45	50
	6HK(0,1)6501006	40	52.4	56.6	60	60
	6HK(1,2)6501306	52	65.6	71.3	70	80
	6HK(1,2)6501506	60	74.0	80.5	80	90
	6HK(1,2)6501806	72	87.3	95.2	90	100
6HK(1,2)6502006	80	95.7	104.4	100	110	
6HK(1,2)6502506	100	117.3	128.3	125	150	

## NOTES:

- (0,1) - 0 = no service disconnect OR 1 = with service disconnect.
- (1,2) - 1 = with service disconnect, no breaker jumper bar OR 2 = with service disconnect & breaker jumper bar.
- MOP = Maximum Overcurrent Protection device; must be HACR type circuit breaker or time delay fuse. Refer to the latest edition of the National Electric Code or in Canada the Canadian electrical Code and local codes to determine correct wire sizing.



## ELECTRICAL DATA FOR MULTI-SOURCE POWER SUPPLY: 208/230-1-60

Air Handlers Models	Heater Models <sup>1,2</sup>	Heater Amps @240V	Min. Circuit Ampacity						MOP <sup>3</sup>					
			208V			230V			208V			230V		
			Circuit						Circuit					
			1st <sup>3</sup>	2nd	3rd	1st <sup>3</sup>	2nd	3rd	1st <sup>3</sup>	2nd	3rd	1st <sup>3</sup>	2nd	3rd
25B	6HK16501306	52	25.0	37.6	–	26.4	41.5	–	25	40	–	30	45	–
	6HK16501506	60	27.9	43.3	–	29.6	47.9	–	30	45	–	30	50	–
	6HK16501806	72	45.3	39.0	–	48.8	43.1	–	50	40	–	50	45	–
	6HK16502006	80	49.6	43.3	–	53.5	47.9	–	50	45	–	60	50	–
37B	6HK16501306	52	25.0	37.6	–	26.4	41.5	–	25	40	–	30	45	–
	6HK16501506	60	27.9	43.3	–	29.6	47.9	–	30	45	–	30	50	–
	6HK16501806	72	45.3	39.0	–	48.8	43.1	–	50	40	–	50	45	–
	6HK16502006	80	49.6	43.3	–	53.5	47.9	–	50	45	–	60	50	–
37C	6HK16501306	52	25.0	37.6	–	26.4	41.5	–	25	40	–	30	45	–
	6HK16501506	60	27.9	43.3	–	29.6	47.9	–	30	45	–	30	50	–
	6HK16501806	72	45.3	39.0	–	48.8	43.1	–	50	40	–	50	45	–
	6HK16502006	80	49.6	43.3	–	53.5	47.9	–	50	45	–	60	50	–
38B	TBD	TBD	TBD	TBD	TBD	TBD	TBD	TBD	TBD	TBD	TBD	TBD	TBD	TBD
38C	6HK16501306	52	25.0	37.6	–	26.4	41.5	–	25	40	–	30	45	–
	6HK16501506	60	27.9	43.3	–	29.6	47.9	–	30	45	–	30	50	–
	6HK16501806	72	45.3	39.0	–	48.8	43.1	–	50	40	–	50	45	–
	6HK16502006	80	49.6	43.3	–	53.5	47.9	–	50	45	–	60	50	–
49C	6HK16501306	52	27.9	37.6	–	29.5	41.5	–	30	40	–	30	45	–
	6HK16501506	60	30.8	43.3	–	32.7	47.9	–	35	45	–	35	50	–
	6HK16501806	72	48.1	39.0	–	51.9	43.1	–	50	40	–	60	45	–
	6HK16502006	80	52.5	43.3	–	56.7	47.9	–	60	45	–	60	50	–
49D	6HK16501306	52	27.9	37.6	–	29.5	41.5	–	30	40	–	30	45	–
	6HK16501506	60	30.8	43.3	–	32.7	47.9	–	35	45	–	35	50	–
	6HK16501806	72	48.1	39.0	–	51.9	43.1	–	50	40	–	60	45	–
	6HK16502006	80	52.5	43.3	–	56.7	47.9	–	60	45	–	60	50	–
	6HK16502506	100	52.5	43.3	21.7	56.7	47.9	24.0	60	45	25	60	50	25
50C	6HK16501306	52	27.9	37.6	–	29.5	41.5	–	30	40	–	30	45	–
	6HK16501506	60	30.8	43.3	–	32.7	47.9	–	35	45	–	35	50	–
	6HK16501806	72	48.1	39.0	–	51.9	43.1	–	50	40	–	60	45	–
	6HK16502006	80	52.5	43.3	–	56.7	47.9	–	60	45	–	60	50	–
50D	6HK16501306	52	27.9	37.6	–	29.5	41.5	–	30	40	–	30	45	–
	6HK16501506	60	30.8	43.3	–	32.7	47.9	–	35	45	–	35	50	–
	6HK16501806	72	48.1	39.0	–	51.9	43.1	–	50	40	–	60	45	–
	6HK16502006	80	52.5	43.3	–	56.7	47.9	–	60	45	–	60	50	–
	6HK16502506	100	52.5	43.3	21.7	56.7	47.9	24.0	60	45	25	60	50	25
61C	6HK16501306	52	27.9	37.6	–	29.5	41.5	–	30	40	–	30	45	–
	6HK16501506	60	30.8	43.3	–	32.7	47.9	–	35	45	–	35	50	–
	6HK16501806	72	48.1	39.0	–	51.9	43.1	–	50	40	–	60	45	–
	6HK16502006	80	52.5	43.3	–	56.7	47.9	–	60	45	–	60	50	–
61D	6HK16501306	52	27.9	37.6	–	29.5	41.5	–	30	40	–	30	45	–
	6HK16501506	60	30.8	43.3	–	32.7	47.9	–	35	45	–	35	50	–
	6HK16501806	72	48.1	39.0	–	51.9	43.1	–	50	40	–	60	45	–
	6HK16502006	80	52.5	43.3	–	56.7	47.9	–	60	45	–	60	50	–
	6HK16502506	100	52.5	43.3	21.7	56.7	47.9	24.0	60	45	25	60	50	25

## NOTES:

- (0,1) - 0 = no service disconnect OR 1 = with service disconnect.
- (1,2) - 1 = with service disconnect, no breaker jumper bar OR 2 = with service disconnect & breaker jumper bar.
- MOP = Maximum Overcurrent Protection device; must be HACR type circuit breaker or time delay fuse. The 1st circuit includes blower motor amps. Refer to the latest edition of the National Electric Code or in Canada the Canadian electrical Code and local codes to determine correct wire sizing.

**ELECTRICAL DATA FOR SINGLE SOURCE POWER SUPPLY: 208/230-3-60**

Air Handler Models	Heater Models <sup>1</sup>	Heater Amps @240V	Field Wiring			
			Min. Circuit Ampacity		MOP <sup>2</sup>	
			208V	230V	208V	230V
25B	6HK36501025	23.1	31.3	33.3	35	35
	6HK36501525	34.6	43.7	47.1	45	50
	6HK36501825	41.6	51.3	55.5	50	60
	6HK46502025 <sup>3</sup>	46.2	56.3	61.0	60	70
37B	6HK36501025	23.1	31.3	33.3	35	35
	6HK36501525	34.6	43.7	47.1	45	50
	6HK36501825	41.6	51.3	55.5	55	60
	6HK46502025 <sup>3</sup>	46.2	56.3	61.0	60	70
37C	6HK36501025	23.1	31.3	33.3	35	35
	6HK36501525	34.6	43.7	47.1	45	50
	6HK36501825	41.6	51.3	55.5	55	60
	6HK46502025 <sup>3</sup>	46.2	56.3	61.0	60	70
38B	TBD	TBD	TBD	TBD	TBD	TBD
38C	6HK36501025	23.1	31.3	33.3	35	35
	6HK36501525	34.6	43.7	47.1	45	50
	6HK36501825	41.6	51.3	55.5	55	60
	6HK46502025 <sup>3</sup>	46.2	56.3	61.0	60	70
49C	6HK36501025	23.1	34.2	36.4	35	40
	6HK36501525	34.6	46.6	50.2	50	55
	6HK36501825	41.6	54.2	58.6	55	60
	6HK46502025 <sup>3</sup>	46.2	59.2	64.1	60	70
49D	6HK36501025	23.1	34.2	36.4	35	40
	6HK36501525	34.6	46.6	50.2	50	55
	6HK36501825	41.6	54.2	58.6	55	60
	6HK46502025 <sup>3</sup>	46.2	59.2	64.1	60	70
	6HK46502525 <sup>3</sup>	57.7	71.6	77.9	80	80
50C	6HK36501025	23.1	34.2	36.4	35	40
	6HK36501525	34.6	46.6	50.2	50	55
	6HK36501825	41.6	54.2	58.6	55	60
	6HK46502025 <sup>3</sup>	46.2	59.2	64.1	60	70
50D	6HK36501025	23.1	34.2	36.4	35	40
	6HK36501525	34.6	46.6	50.2	50	55
	6HK36501825	41.6	54.2	58.6	55	60
	6HK46502025 <sup>3</sup>	46.2	59.2	64.1	60	70
	6HK46502525 <sup>3</sup>	57.7	71.6	77.9	80	80
61C	6HK36501025	23.1	34.2	36.4	35	40
	6HK36501525	34.6	46.6	50.2	50	55
	6HK36501825	41.6	54.2	58.6	55	60
	6HK46502025 <sup>3</sup>	46.2	59.2	64.1	60	70
61D	6HK36501025	23.1	34.2	36.4	35	40
	6HK36501525	34.6	46.6	50.2	50	55
	6HK36501825	41.6	54.2	58.6	55	60
	6HK46502025 <sup>3</sup>	46.2	59.2	64.1	60	70
	6HK46502525 <sup>3</sup>	57.7	71.6	77.9	80	80

**NOTES:**

1. 6HK3 = 3-Phase with terminal block connections only, 6HK4 = 3-Phase with service disconnect
2. MOP = Maximum Overcurrent Protection device; must be HACR type circuit breaker or time delay fuse. The 1st circuit includes blower motor amps. Refer to the latest edition of the National Electric Code or in Canada the Canadian electrical Code and local codes to determine correct wire sizing.
3. The 20kW and 25kW heater models (6HK46502025 and 6HK46502525) come with circuit breakers standard. Single source power MCA and MOP requirements are given here only for reference if used with field installed single point power modification.

**ELECTRICAL DATA FOR MULTI-SOURCE POWER SUPPLY: 208/230-3-60**

Air Handlers Models	Heater Models <sup>1</sup>	Heater Amps @240V	Min. Circuit Ampacity				MOP <sup>2</sup>			
			208V		230V		208V		230V	
			Circuit				Circuit			
			1st <sup>2</sup>	2nd	1st <sup>2</sup>	2nd	1st <sup>2</sup>	2nd	1st <sup>2</sup>	2nd
25B	6HK46502025	46.2	31.3	25.0	33.3	27.6	35	25	35	30
37B	6HK46502025	46.2	28.8	22.6	30.6	25.0	35	25	35	30
37C	6HK46502025	46.2	31.3	25.0	33.3	27.6	35	25	35	30
38B	TBD	TBD	TBD	TBD	TBD	TBD	TBD	TBD	TBD	TBD
38C	6HK46502025	46.2	31.3	25.0	33.3	27.6	35	25	35	30
49C	6HK46502025	46.2	34.1	25.0	36.4	27.6	35	25	40	30
49D	6HK46502025	46.2	34.1	25.0	36.4	27.6	35	25	40	30
	6HK46502525	57.7	40.4	31.3	43.3	34.6	45	35	45	35
50C	6HK46502025	46.2	9.1	0.0	8.8	0.0	35	25	40	30
	6HK46502525	57.7	9.1	0.0	8.8	0.0	45	35	45	35
50D	6HK46502025	46.2	27.9	18.8	29.5	20.7	35	25	40	30
	6HK46502525	57.7	31.7	22.6	33.7	25.0	45	35	45	35
61C	6HK46502025	46.2	34.1	25.0	36.4	27.6	35	25	40	30
61D	6HK46502025	46.2	34.1	25.0	36.4	27.6	35	25	40	30
	6HK46502525	57.7	40.4	31.3	43.3	34.6	45	35	45	35

**NOTES:**

1. The 20kW and 25kW heater models (6HK46502025 and 6HK46502525) come with service disconnects standard.
2. MOP = Maximum Overcurrent Protection device; must be HACR type circuit breaker or time delay fuse. The 1st circuit includes blower motor amps. Refer to the latest edition of the National Electric Code or in Canada the Canadian electrical Code and local codes to determine correct wire sizing.

**POWER WIRING - LINE CONNECTIONS**

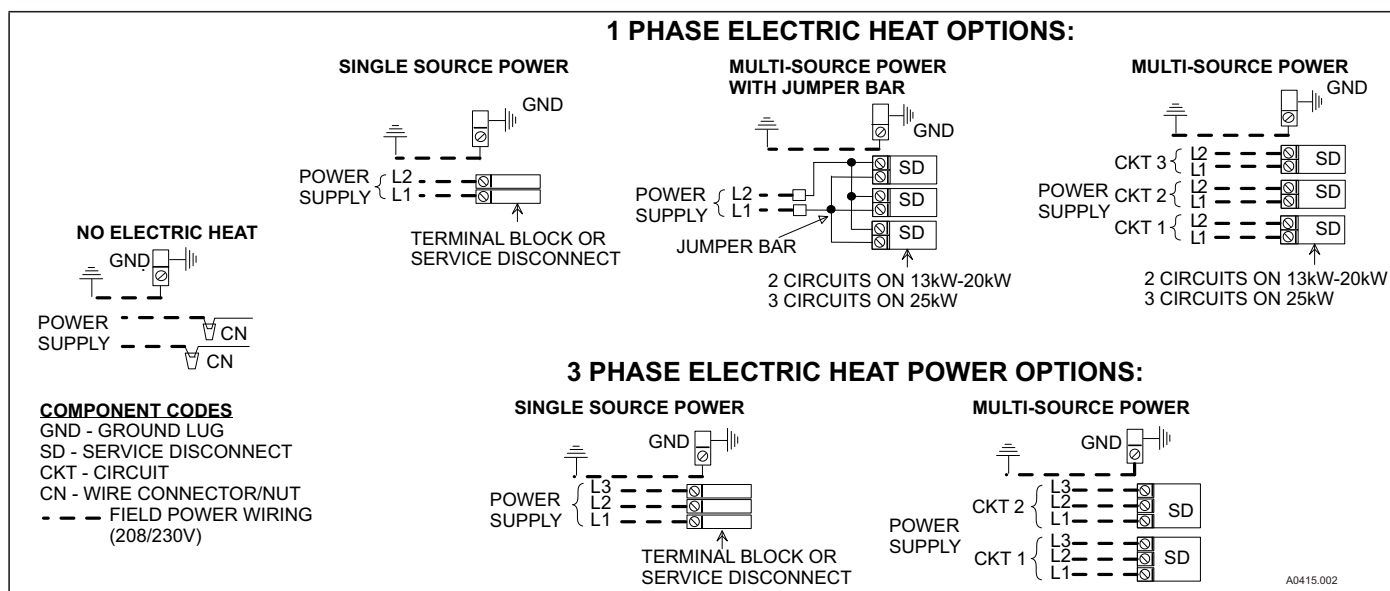

**ACCESSORIES**

Refer to Price Manual for specific model numbers where not shown.

**TXV Kits** - Air handlers are shipped with “Flex-coils” without a factory installed metering device. For added flexibility, an R-22 or R-410A TXV or piston can be field installed to meet your refrigerant choice. All TXV kits are chatleff style and require no brazing to install. Some models are available with a factory installed TXV.

**Electric Heaters** - 6HK models shown under electrical data include sequential operation and temperature dual limit switches for safe, efficient operation. Service disconnects are provided where shown.

SINGLE SOURCE POWER ACCESSORIES (SINGLE PHASE)	
S1-02435670000	For heat kits with 2 service disconnects.
S1-02435671000	For heat kits with 3 service disconnects.
SINGLE SOURCE POWER ACCESSORY (THREE PHASE)	
S1-32436041000	Contains a terminal block and wiring to connect service disconnects together.

**Combustible Floor Base Accessory** - If an electric heat accessory which is rated for greater than zero clearance to combustible surfaces is installed in these air handlers in the downflow operating positions on a combustible floor, one of the following combustible floor base accessory models is required: S1-1FB1917, S1-1FB1921, S1-1FB1924.

**Breaker Moisture Seal Accessory** - A clear circuit breaker moisture barrier seals the breakers from humidity and dust. The flexibility of the clear cover allows circuit breakers to be turned ON or OFF without removing the cover. The cover firmly attaches to the access panel around the circuit breakers with the use of double backed adhesive tape. To ensure that moisture or dust does not contaminate circuit breakers, an S1-02435672000, Circuit Breaker, Cover Seal may be ordered.

**Thermostat** - Use the compatible *Hx™* thermostat with the AVV air handler for the communicating system to function. Use only the York S1-THXU280\* touch screen thermostat with proprietary (patent-pending) hexagon interface. For more information, see the thermostat section of the Product Equipment Catalog.

**COMBUSTIBLE FLOOR BASE ACCESSORY**

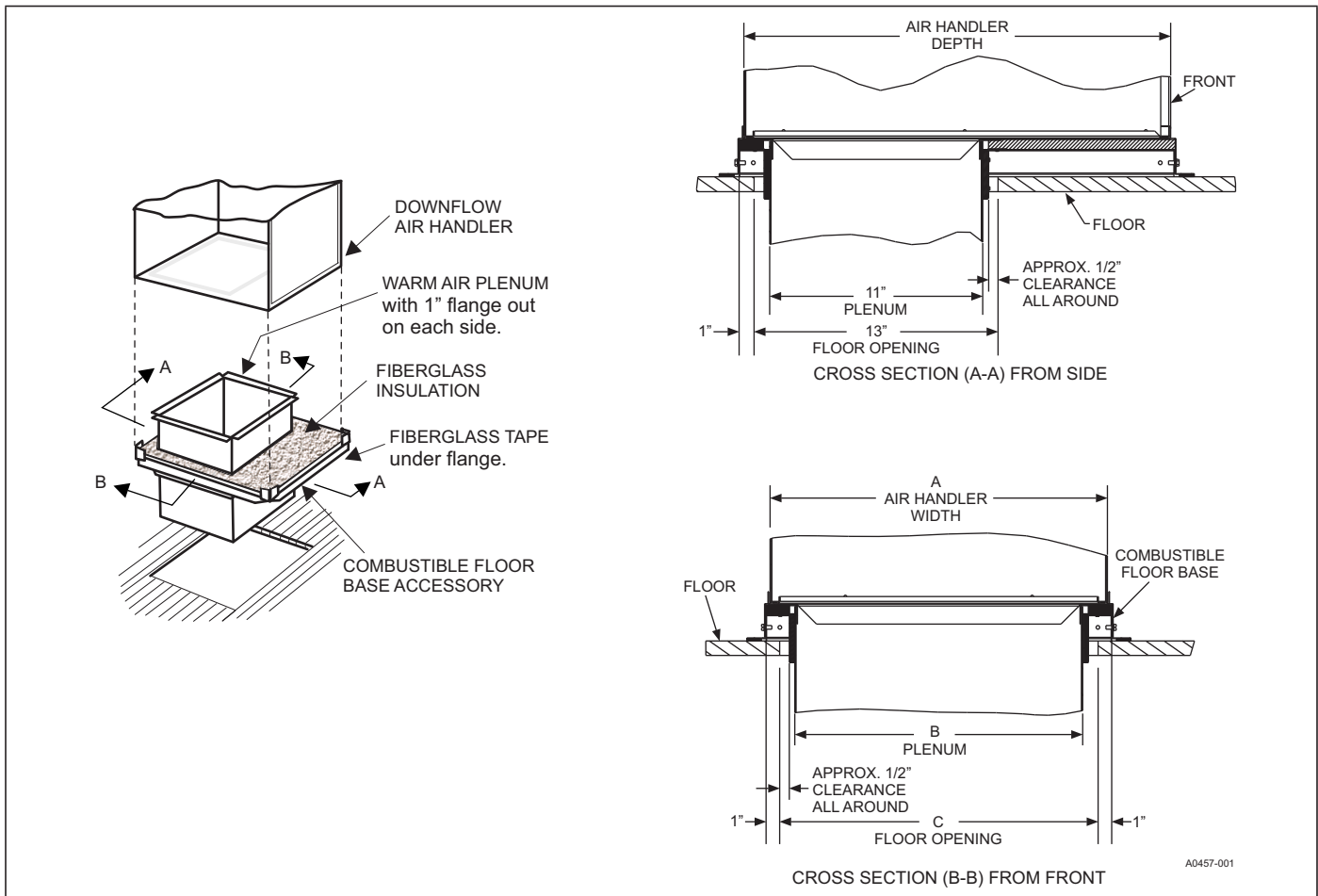

Floor Base Models	Used with	Dimensions		
		A	B	C
1FB1917	AVV25B / AVV37B / AVV38B	17.5	14.0	16.0
1FB1921	AVV37C / AVV38C / AVV49C / AVV61C	21.0	17.5	19.5
1FB1924	AVV49D / AVV50D / AVV61D	24.5	21.0	23.0

**LIMITATIONS**

These units must be wired and installed in accordance with all national and local safety codes.

Voltage limits are as follows:

Air Handler Voltage	Voltage code	Normal Operating Voltage Range <sup>1</sup>
208/230-1-60	06	187-253

1. Rated in accordance with ARI Standard 110, utilization range "A".

Airflow must be within the minimum and maximum limits approved for electric heat, evaporator coils and outdoor units.

**TYPICAL APPLICATIONS**

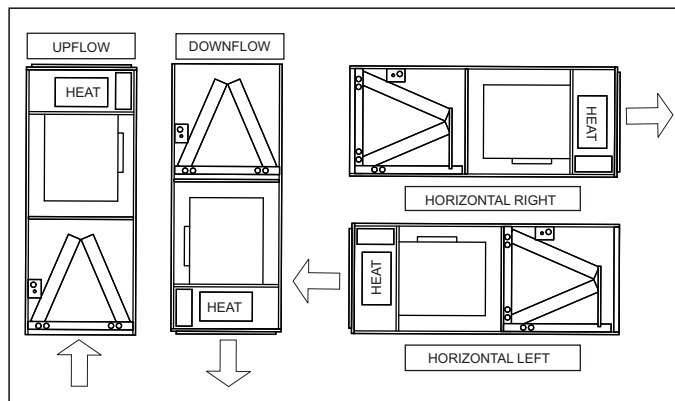

**TYPICAL THERMOSTAT CONNECTION**

**Cooling Models with and without Electric Heat Wiring**

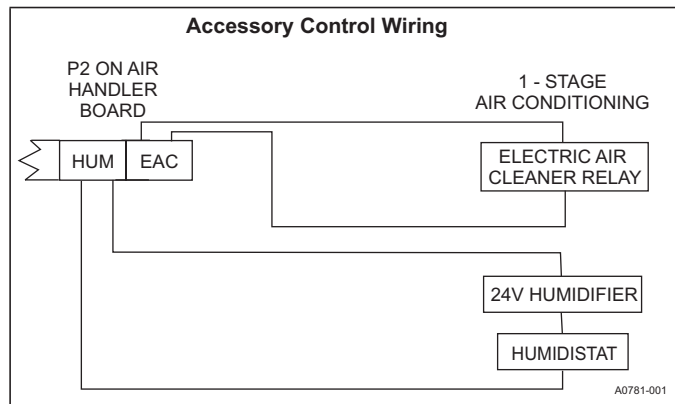

\* Optional dehumidification humidistat switch contacts open on humidity rise.

**NOTES:**

1. "Y/Y2" Thermostat wire must be connected for full CFM and applications requiring 60 second blower off delay for SEER enhancement.
2. Move HUM STAT jumper on air handler control board to YES position if humidistat is used.
3. For heat pump applications - set AC/HP jumper on air handler control board to the HP position.

**Air Handler with Communicating AC or HP**

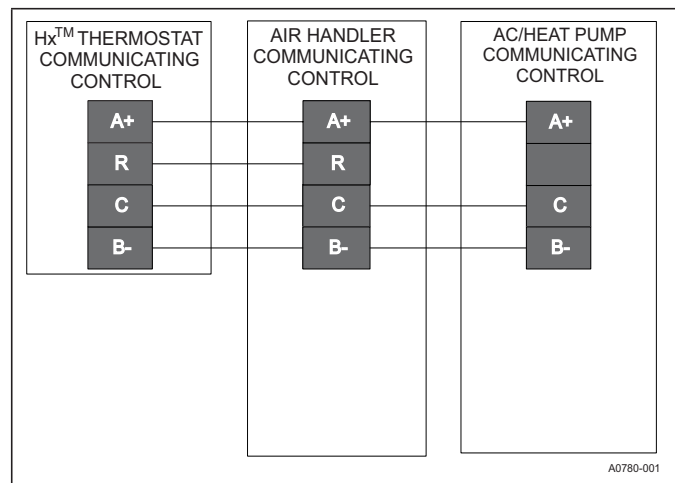

**TEMPORARY REPAIR MODE COOLING AIR FLOW DATA (CFM)<sup>1,3, 4</sup>**  
**(Only applicable when wired for temporary operation in REPAIR MODE. Not applicable to normal variable capacity operation.)**

High/Low Speed Cooling and Heat Pump CFM							
Cool Tap	ADJ Tap <sup>2</sup>	AVV25B	AVV37B	AVV37C	AVV38B	AVV38C	AVV49C
		High	High	High	High	High	High
A	B	1350	1350	1350	TBD	1596	1760
B	B	1238	1238	1238	TBD	1400	1540
A	A	1200	1200	1200	TBD	1425	1600
B	A	1100	1100	1100	TBD	1250	1400
A	C	1050	1050	1050	TBD	1268	1424
C	B	1125	1125	1125	TBD	1344	1320
B	C	963	963	963	TBD	1113	1246
D	B	900	900	900	TBD	1120	1100
C	A	1000	1000	1000	TBD	1200	1200
D	A	800	800	800	TBD	1000	1000
C	C	875	875	875	TBD	1068	1068
D	C	700	700	700	TBD	890	890

Cool Tap	ADJ Tap <sup>2</sup>	AVV49D	AVV50C	AVV50D	AVV61C	AVV61D	
		High	High	High	High	High	
A	B	1760	1760	1760	1860	1935	
B	B	1540	1540	1540	1840	1772	
A	A	1600	1600	1600	1750	1800	
B	A	1400	1400	1400	1600	1575	
A	C	1424	1424	1424	1531	1665	
C	B	1320	1320	1320	1581	1491	
B	C	1246	1246	1246	1400	1457	
D	B	1100	1100	1100	1323	1350	
C	A	1200	1200	1200	1375	1325	
D	A	1000	1000	1000	1150	1200	
C	C	1068	1068	1068	1203	1226	
D	C	890	890	890	1006	1110	

**NOTES:**

- Air handler units have been tested to UL 1995 / CSA 22.2 No. 236 standards up to 0.50" wc. external static pressure.  
 Dry coil conditions only, tested without filters.  
 For optimal performance, external static pressures of 0.2" to 0.5" are recommended. Heating applications tested at 0.50" w.c. esp. Above 0.5" CFM is reduced by 2% per 0.1" increase in static.
- The ADJ tap does not affect the HEAT tap setting.  
 Low speed cooling used only with two stage outdoor units. Speed is preset to 65% of high speed.  
 Dehumidification speed is 85% of jumper selected COOL tap and ADJUST tap.  
 When operating in both heat pump and electric heat modes, the airflow (CFM) will be per HEAT tap CFM values only.  
 At some settings, LOW COOL and/or LOW HEAT airflow may be lower than what is required to operate an airflow switch on certain models of electronic air cleaners. Consult the instructions for the electronic air cleaner for further details.  
 Airflow (CFM) indicator light (LED2) flashes once for every 100 CFM (i.e.: 12 flashes is 1200 CFM) - blinks are approximate +/- 10% of actual CFM.
- All CFMs are shown at 0.5" w.c. external static pressure. These units have variable-speed ECM motors that automatically adjust to provide constant CFM from 0.0" to 0.4" wc. external static pressure. From 0.4" to 0.8" external static pressure, CFM is reduced by 2% per 0.1" static pressure. Operation of these units on duct systems with external static pressure greater than **0.8"** is not recommended.  
 At some settings, airflow may be lower than what is required to operate an airflow switch on certain models of electronic air cleaners. Consult the instructions for the electronic air cleaner for further details.  
 Data is for 208V or 230V.
- The ADJ "D" tap should not be used.  
 The outdoor unit controls the indoor fan speed during heat pump heating or cooling operation.  
 The indoor circulating only fan speed operates at approximately 63% of the HIGH cooling speed tap setting.

**ELECTRIC HEATING AIR FLOW DATA (CFM)<sup>1, 2, 3, 4</sup>**

High/Low Speed Heat CFM												
Heat Tap	AVV25B		AVV37B		AVV37C		AVV38B		AVV38C		AVV49C	
	High	Low	High	Low	High	Low	High	Low	High	Low	High	Low
A	1225	1020	1225	1020	1425	1150	TBD	TBD	1430	1200	1650	1200
B	1150	950	1150	950	1150	1000	TBD	TBD	1375	1150	1550	1150
C	950	750	950	750	925	925	TBD	TBD	1150	1050	1375	1050
D	725	725	725	725	675	675	TBD	TBD	900	900	1150	1000

Heat Tap	AVV49D		AVV50C		AVV50D		AVV61C		AVV61D			
	High	Low	High	Low	High	Low	High	Low	High	Low		
A	1650	1150	1650	1200	1650	1150	1850	1250	1825	1150		
B	1600	1050	1550	1150	1600	1050	1775	1200	1775	1050		
C	1325	1000	1375	1050	1325	1000	1570	1150	1570	1000		
D	1125	780	1150	1000	1125	780	1370	1050	1375	950		

**NOTES:**

- Air handler units have been tested to UL 1995 / CSA 22.2 No. 236 standards up to 0.50" wc. external static pressure.  
Dry coil conditions only, tested without filters.  
For optimal performance, external static pressures of 0.2" to 0.5" are recommended. Heating applications tested at 0.50" w.c. esp. Above 0.5" CFM is reduced by 2% per 0.1" increase in static.
- The ADJ tap does not affect the HEAT tap setting.  
Airflow (CFM) indicator light (LED2) flashes once for every 100 CFM (i.e.: 12 flashes is 1200 CFM) - blinks are approximate +/- 10% of actual CFM.
- All CFM are shown at 0.5" w.c. external static pressure. These units have variable-speed ECM motors that automatically adjust to provide constant CFM from 0.0" to 0.4" WC. external static pressure. From 0.4" to 0.8" external static pressure, CFM is reduced by 2% per 0.1" static pressure. Operation of these units on duct systems with external static pressure greater than **0.8"** is not recommended.
- Airflow may be lower than what is required to operate an airflow switch on certain models of electronic air cleaners. Consult the instructions for the electronic air cleaner for further details.

# NOTES